



More Easy, More Safe, More Efficiency

Spiral Conveyor

www.sz-apollo.com

Spiral Conveyor

5030 Logistics Type



APOLLO Spiral Conveyor

- High efficiency, Small space occupation
- Low noise running, quiet and comfortable

- Max speed 60m/min, Max capacity 50kg/m
- Built-in protection, able to run 7×24 hours



Characteristics and Parameters

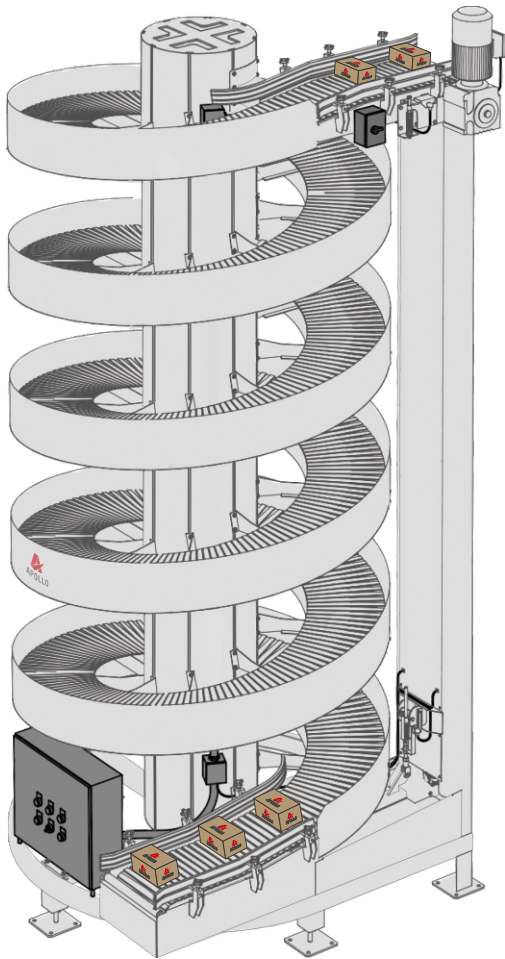

The vertical conveying capacity of spiral conveyor is faster than other lifter.

APOLLO Spiral Conveyor adopts modular design, multiple specifications available to meet different size of goods. It is suitable for vertical transportation for cartons, plastic totes and partial woven bags etc.

APOLLO Spiral Conveyor uses low friction slat and rolling friction bearing, which has the characteristics of low wear and low noise.

APOLLO Spiral Conveyor is widely used in food and beverage, pharmaceutical, fast consumer goods, clothing, electronic products and other industries.

1. Machine Advantages

Low friction structure, stable and reliable
Low noise running, quiet and comfortable

2. Safety Protection

Stuck goods/ overload protection
Automatic protection for loose chain

3. Slat

Inserted slat
Easy replacement

4. Chain

Automatically tensioning chain
By Spring/ Pneumatic

5. Center Column

Aluminum profile structure, accurate positioning
Exquisite and beautiful appearance

6. Installation and Maintenance

Easy installation, deliver in fully assembled or disassembled
Convenient and fast maintenance

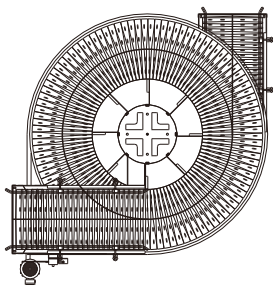

A Type : 90°

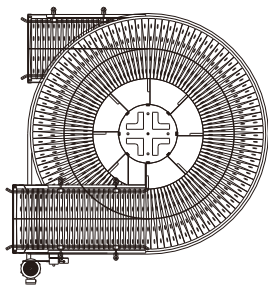

B Type : 180°

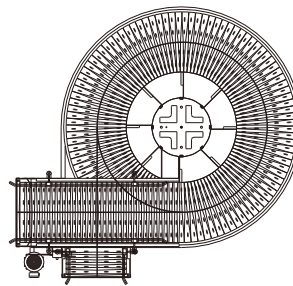

C Type : 270°

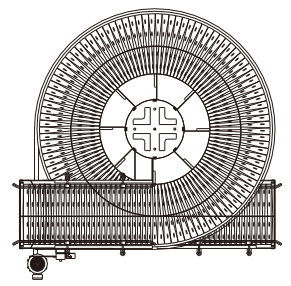

D Type : 360°

Model	Slat Width	Abutting Conveyor Width	Run Speed	Rated Load	Diameter	Machine Height	Frame Material
5030-500	500mm	580mm	≤40m/min ≤60m/min	≤50kg/m	φ 2200mm	Single unit ≤10m (if higher than 10m, can superpose multiple units)	Carbon steel Stainless steel 304
5030-650	650mm	730mm	≤40m/min ≤60m/min	≤50kg/m	φ 2550mm	Single unit ≤10m (if higher than 10m, can superpose multiple units)	Carbon steel Stainless steel 304

Remark: The above is APOLLO standard models, if need other specification, please contact our sales.

Spiral Conveyor

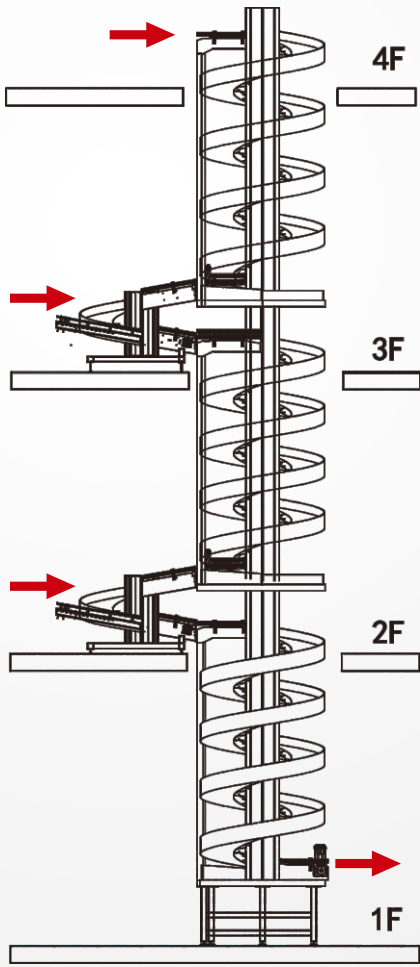

Three infeed One outfeed

- Different floors multiple entry
- Multiple units superposition, spiral transportation
- Safe and reliable, easy maintenance
- Effectively reduce the cost of vertical transportation

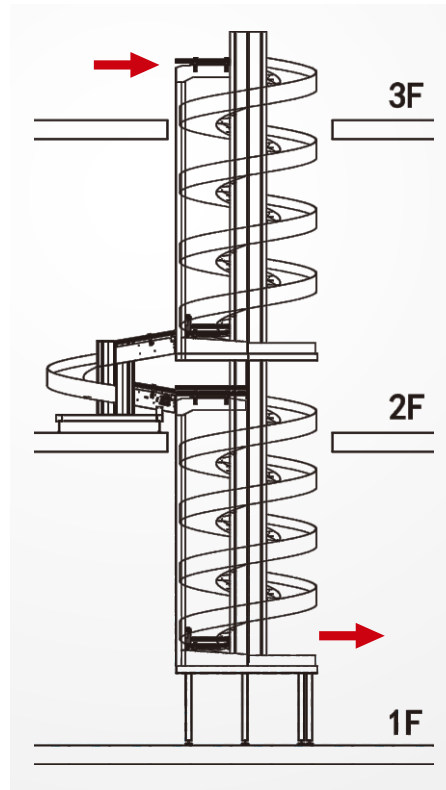

**One infeed One outfeed
(2 units superposition)**

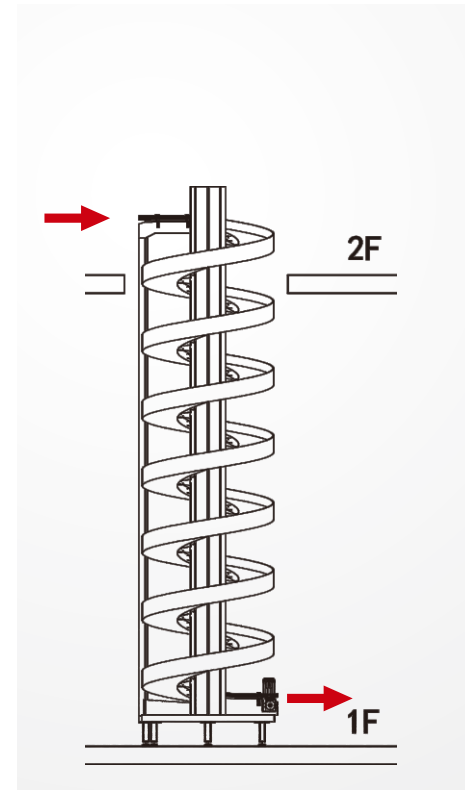

One infeed One outfeed

APOLLO Spiral Conveyor adopts modular parts and the inserted slat by injection moulding, which has good toughness and strength.

APOLLO Spiral Conveyor uses a unique low friction guide structure, bearings with high precision and low friction coefficient, high load traction chain, rolling track made of wear-resistant materials.

APOLLO Spiral Conveyor is simple control, stable and reliable operation, easy maintenance.



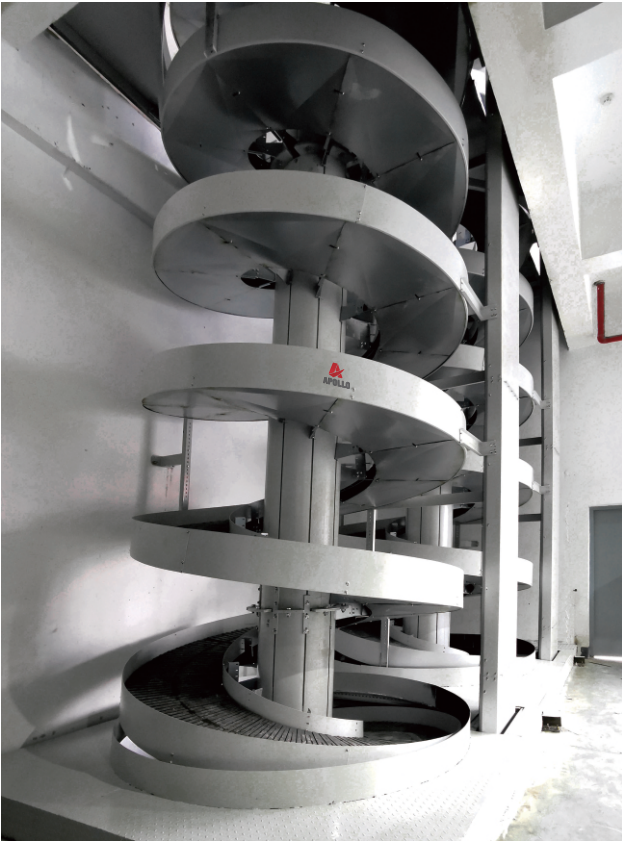

Spiral Conveyor is mainly used for the transportation of goods with height difference, compared with continuous lifter, it's more efficient, reliable and space saving as the vertical conveyor equipment.

Spiral Conveyor can be combined with the infeed and oufeed conveyors to compose a complete set of lifting system, to meet the vertical transportation needs for large logistic centers.





APOLLO MEDIA CENTER

You can find more from our website:

- Rich resource media center and selection guide on how to choose APOLLO products.
- Application reports from different industries cover a variety of operational possibilities.
- Quick product survey and contact information of our system consultants.

www.sz-apollo.com



WeChat
consultation



WeChat public
account

 amy@sz-apollo.com

 +86-512-6569 8859

 +86-151 5140 8535 Amy

 No. 5527 Wuzhong avenue, Wuzhong district, Suzhou, China