



More Easy, More Safe, More Efficiency

Spiral Conveyor

www.sz-apollo.com



Spiral Conveyor is mainly used for the transportation of goods with height difference, compared with continuous lifter, it's more efficient, reliable and space saving as the vertical conveyor equipment.

Spiral Conveyor can be combined with the infeed and oufeed conveyors to compose a complete set of lifting system, to meet the vertical transportation needs for large logistic centers.



Spiral Conveyor

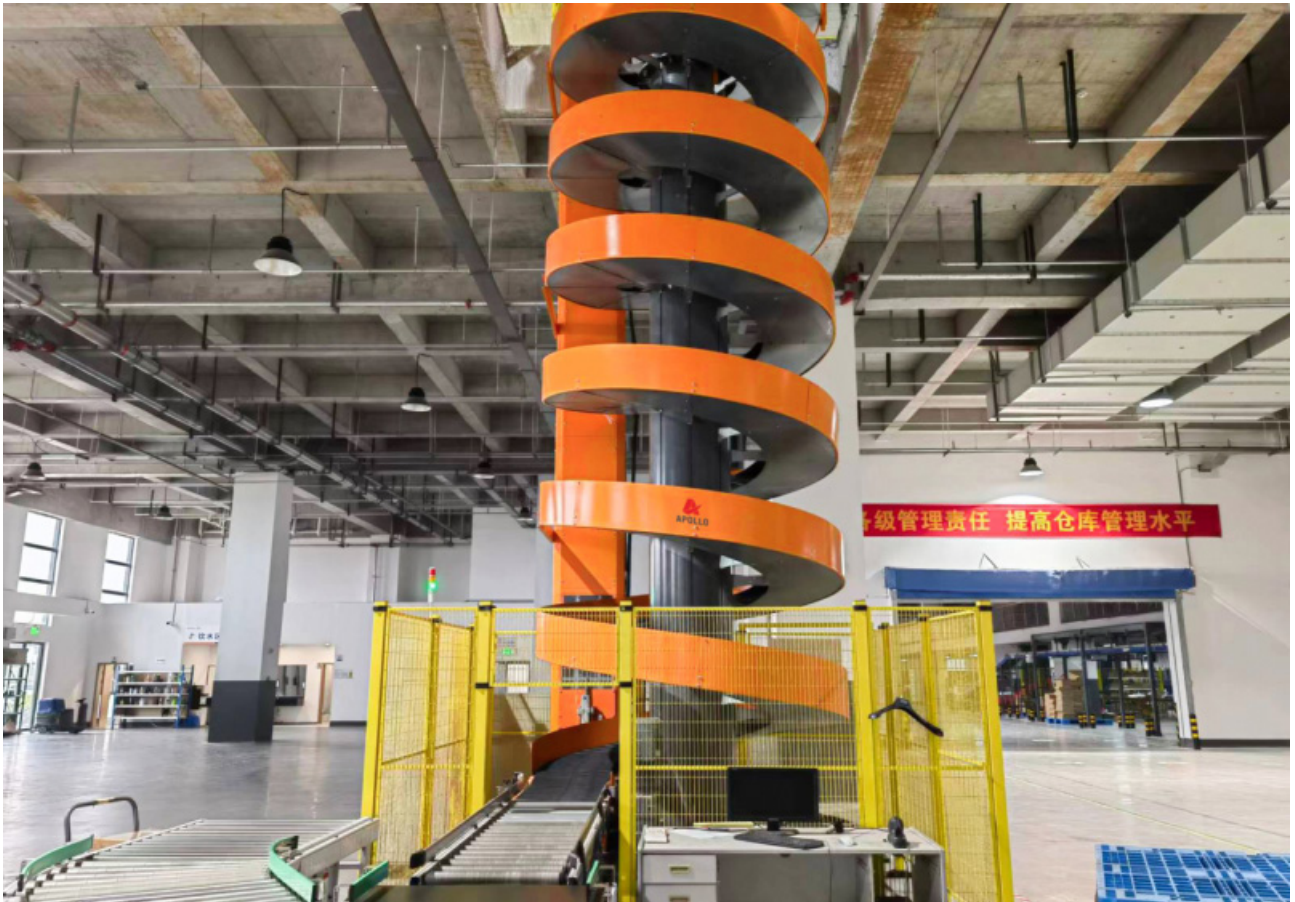

APOLLO Spiral Conveyor

- High efficiency, Small space occupation
- Low noise running, quiet and comfortable

- Max speed 60m/min, Max capacity 50kg/m
- Built-in protection, able to run 7×24 hours

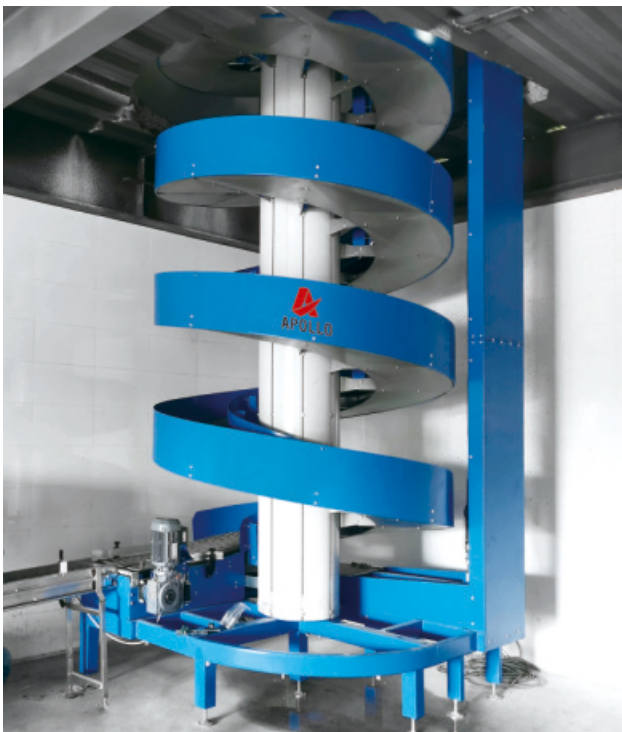

Characteristics and Parameters

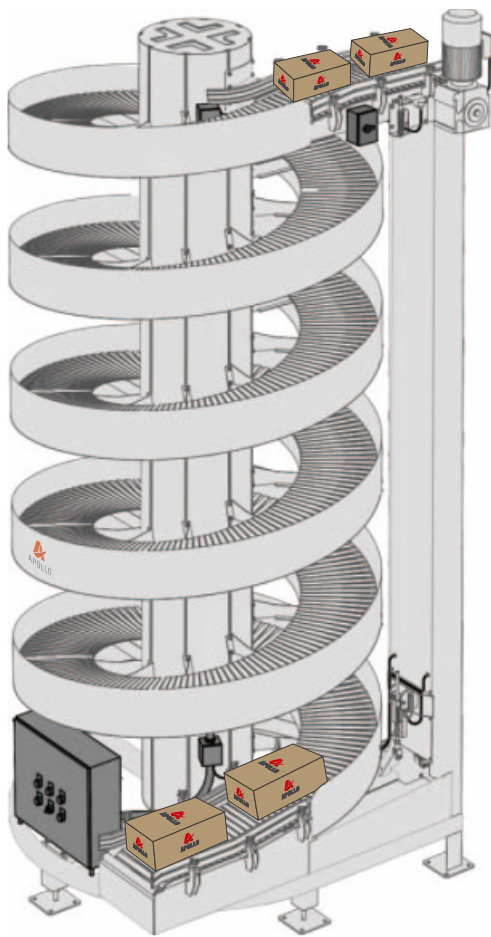

Suitable for heavy goods up to 50kg, 7*24h operation and speed up to 60m/min with stable running.

The vertical conveying capacity of spiral conveyor is faster than other lifter.

APOLLO Spiral Conveyor adopts modular design, multiple specifications available to meet different size of goods. It is suitable for vertical transportation for cartons, plastic totes and partial woven bags etc.

APOLLO Spiral Conveyor uses low friction slat and rolling friction bearing, which has the characteristics of low wear and low noise.

APOLLO Spiral Conveyor is widely used in food and beverage, pharmaceutical, fast consumer goods, clothing, electronic products and other industries.

1. Machine Advantages

Low friction structure, stable and reliable
Low noise running, quiet and comfortable

2. Safety Protection

Stuck goods/ overload protection
Automatic protection for loose chain

3. Slat

Inserted slat
Easy replacement

4. Chain

Automatically tensioning chain
By Spring/ Pneumatic

5. Center Column

Aluminum profile structure, accurate positioning
Exquisite and beautiful appearance

6. Installation and Maintenance

Easy installation, deliver in fully assembled or disassembled
Convenient and fast maintenance

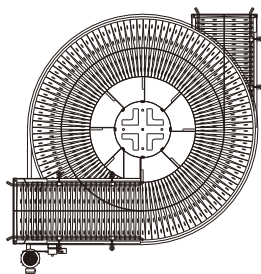

A Type : 90°

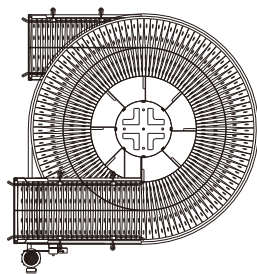

B Type : 180°

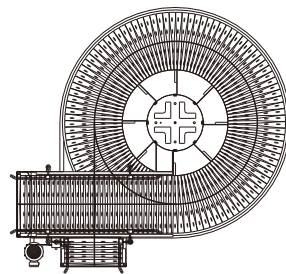

C Type : 270°

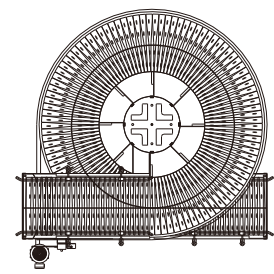

D Type : 360°

Model	Slat Width	Abutting Conveyor Width	Run Speed	Rated Load	Diameter	Machine Height	Frame Material
A-500	500mm	≤580mm	≤40m/min ≤60m/min	≤50kg/m	φ 2200mm	≤11m (Higher height available by superposition)	Carbon steel Stainless steel 304
A-650	650mm	≤730mm	≤40m/min ≤60m/min	≤50kg/m	φ 2550mm	≤11m (Higher height available by superposition)	Carbon steel Stainless steel 304
A-900	900mm	≤980mm	≤40m/min ≤60m/min	≤50kg/m	φ 4000mm	≤9m (Higher height available by superposition)	Carbon steel Stainless steel 304

Remark: The above is APOLLO standard models, if need other specification, please contact our sales.

Spiral Conveyor

5030 Logistics Type

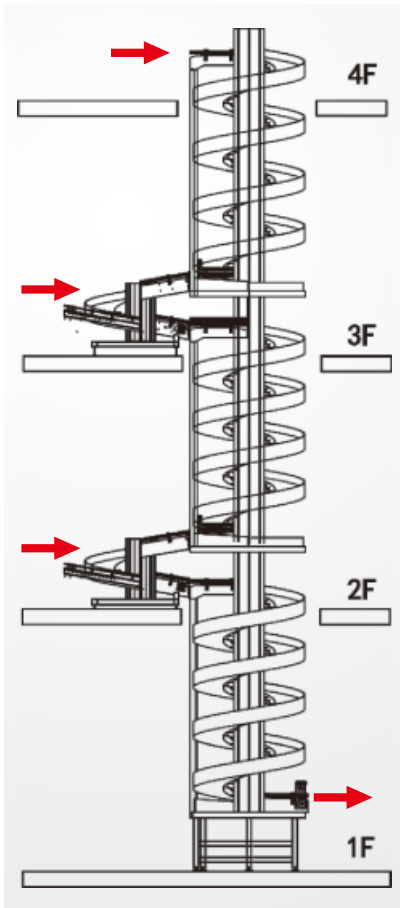

Three infeed One outfeed

- Different floors multiple entry
- Multiple units superposition, spiral transportation
- Safe and reliable, easy maintenance
- Effectively reduce the cost of vertical transportation

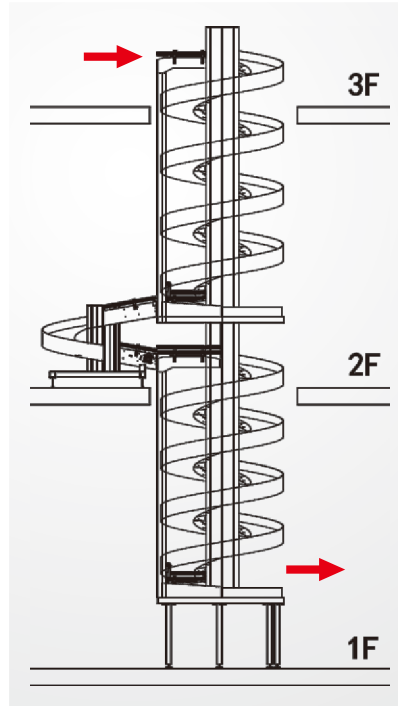

One infeed One outfeed
(2 units superposition)

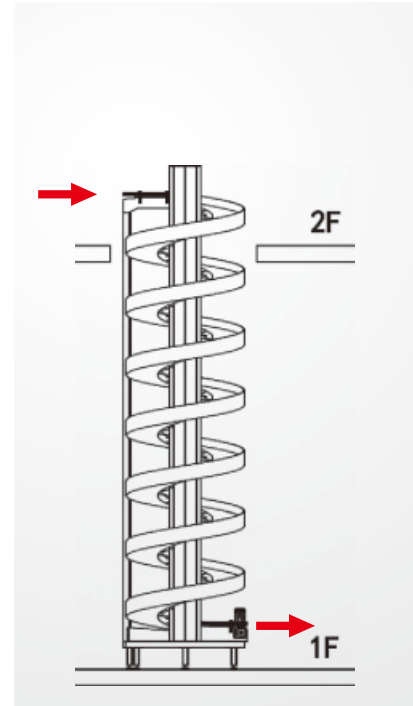

One infeed One outfeed

APOLLO Spiral Conveyor adopts modular parts and the inserted slat by injection moulding, which has good toughness and strength.

APOLLO Spiral Conveyor uses a unique low friction guide structure, bearings with high precision and low friction coefficient, high load traction chain, rolling track made of wear-resistant materials.

APOLLO Spiral Conveyor is simple control, stable and reliable operation, easy maintenance.



Production of Spiral Conveyor



Production in factory



Performance test

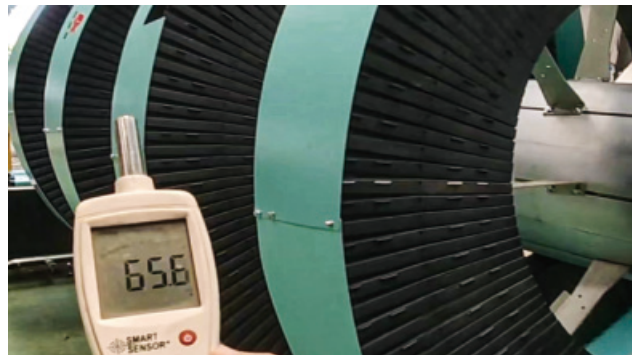
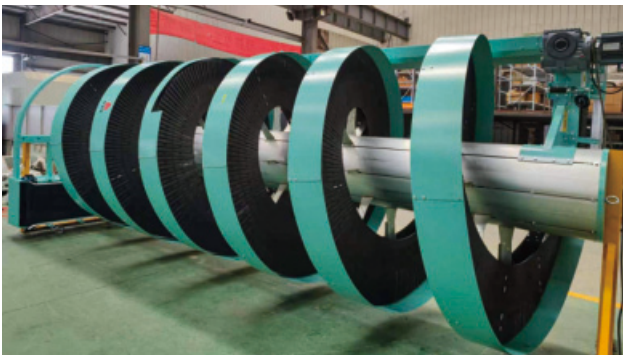

Commissioning before delivery

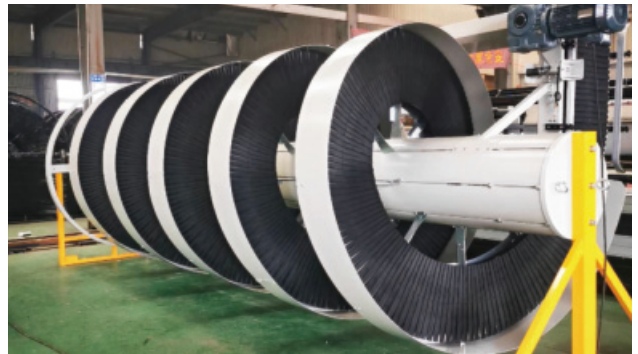

Transportation



Delivery of Spiral Conveyor



Installation



Delivery and operation



Application of Spiral Conveyor



Application of Spiral Conveyor





APOLLO MEDIA CENTER

You can find more from our website:

- Rich resource media center and selection guide on how to choose APOLLO products.
- Application reports from different industries cover a variety of operational possibilities.
- Quick product survey and contact information of our system consultants.

www.sz-apollo.com



WeChat
consultation



WeChat public
account

 amy@sz-apollo.com

 +86-512-6569 8859

 +86-151 5140 8535 Amy

 No. 5527 Wuzhong avenue, Wuzhong district, Suzhou, China